

FRR 500 | FRR 500 Crew
FRD 500



FRR 500 Crew



FRR 500

AUSTRALIA'S TOP SELLING TRUCK BRAND SINCE 1989. Truck tracker 2009.

AT A GLANCE

GVM	10,400 kg
GCM	16,000 kg
Power	154 kW @ 2,600 rpm
Torque	637 Nm @ 1,600 - 2,600 rpm

UPGRADE OPTIONS

AMT Pack:

- Automated Manual Transmission (AMT)

ADVANCED TECHNOLOGY

- Emissions: Euro IV - exceeds ADR80/02
- Driver airbag with seatbelt pretensioner
- Anti-lock Braking System (ABS)
- Anti Skid Regulator (ASR) - except crew
- Hill Start Aid (HSA)
- Cruise control
- Electric mirrors
- Front stabiliser bar
- ISRI 6860 seat with integrated seatbelt
- Electronically controlled 4-bag air rear suspension (FRD model)



RELIABILITY IS EVERYTHING **ISUZU**

Driveline & Chassis Specifications

ENGINE: SiTEC SERIES II 205 (ISUZU 4HK1-TCS)

- Type:** 4 cylinder 16 valve SOHC
- Displacement:** 5,193 cc
- Compression Ratio:** 17.5:1
- Bore x Stroke:** 115 mm x 125 mm
- Max power** (DIN-NET): 154 kW (207 HP) @ 2,600 RPM
(JIS Gross): 160 kW (214 HP) @ 2,600 RPM
- Max torque** (DIN-NET): 637 Nm (470 lb.ft) @ 1,600 - 2,600 RPM
(JIS Gross): 659 Nm (486 lb.ft) @ 1,600 - 2,600 RPM
- Induction system:** Electronically controlled variable nozzle turbocharger with air-to-air intercooler.
- Fuel injection:** Direct injection high pressure common rail system.
- Emission control system:** Two-stage electronically controlled cooled EGR with exhaust Diesel Particulate Diffuser (DPD). ADR 80/02 (Euro IV) compliant.
- Engine driven PTO (FRR 500 PTO model only):**
- Constant mesh. Rotates at 0.7 x engine speed.
 - 353 Nm maximum output torque.
 - Anti-clockwise rotation when viewed from rear of engine.

CLUTCH

- Standard model:**
- Air assisted hydraulic control. Single plate 352 mm diameter.
 - Total lining area: 1,164 cm²

AMT Pack:

- Fully automated hydraulically controlled wet clutch and fluid coupling with lock up.

TRANSMISSION

ISUZU MZW-6P

- Synchromesh on gears 2-6. Triple cone synchromesh on 2nd and 3rd gears. Integral oil pump provides full pressure lubrication.
- PTO provision on LHS of transmission case. PTO drive from mainshaft gear.
- Gear ratios (:1)

1st	2nd	3rd	4th	5th	6th	Rev
6.615	4.095	2.358	1.531	1.000	0.722	6.615

Standard model:

- 6 speed manual with air assisted shift.

AMT Pack:

- 6 speed Automated Manual Transmission (AMT) with both fully automatic and clutchless manual operation modes.

AXLES

Front: Isuzu F041

- Reverse Elliot I-beam. 4,100 kg capacity.

Rear: Isuzu R077

- Full floating Banjo type. 7,700 kg capacity.
- Drive ratio: 5.125:1

SUSPENSION

Front:

- Single stage alloy steel taper leaf springs (except FRR 500 PTO). Single stage alloy steel multi leaf springs (FRR 500 PTO).

- Double acting hydraulic shock absorbers. Stabiliser bar.

Rear (FRR 500):

- Multi leaf main spring, multi leaf helper spring.

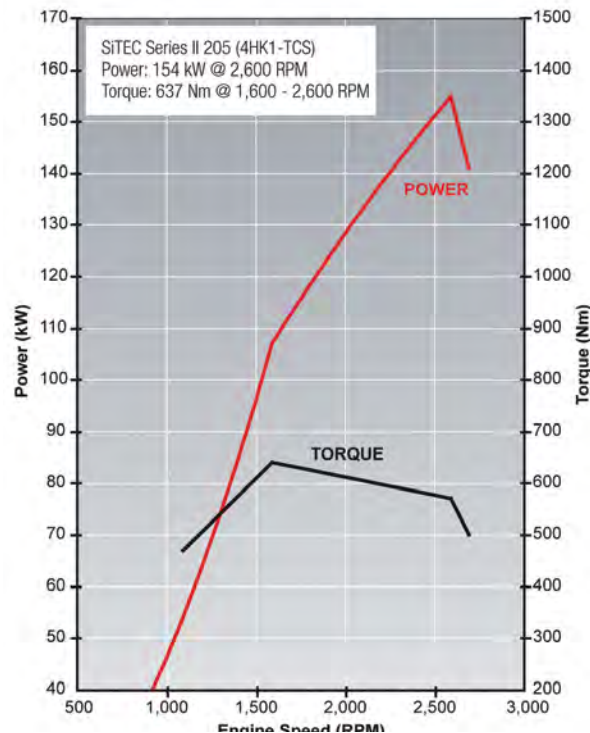

Rear (FRD 500):

- Isuzu 4-bag electronically controlled air suspension system.
- Double acting hydraulic shock absorbers. Stabiliser bar.

BRAKES

- Dual circuit air over hydraulic front and rear drum brakes.
- ABS.
- ASR traction control (except crew).
- Hill Start Aid (HSA).
- Front drum size: 320 x 120 mm
- Rear drum size: 320 x 145 mm
- Spring park brake.
- Air controlled exhaust brake.
- Air dryer.

STEERING

- Power assisted recirculating ball steering.
- Gear ratio: 16:1 - 18.8:1
- Turns lock to lock: 4.1
- Maximum angle: 52° (inside wheel) / 39° (outside wheel)

WHEELS AND TYRES

- 17.5 x 6.00J six stud steel wheels.
- **Steer axle:** 9.5R17.5 129/127L Michelin XZA Tubeless
- **Drive axle:** 9.5R17.5 129/127L Michelin XZA Tubeless (except FRR 500 PTO)
9.5R17.5 129/127L Michelin XZT Tubeless (FRR 500 PTO)
- Maximum tyre rating:
Steer axle: 3,700 kg
Drive axle: 7,000 kg
- Spare wheel and tyre assembly with winch type carrier.

CHASSIS FRAME

- Cold rivetted ladder frame with parallel side rails. HT540A high tensile weldable steel sidemembers.
- Frame dimensions:
 - Side rail (mm): 225 x 70 x 6.0
 - Rear frame width (mm): 840

FUEL TANK

- Frame mounted 200L steel fuel tank.
- Lockable fuel cap.

ELECTRICAL SYSTEM

- 24 volt electrical system.
- **Single cab:** 60 amp alternator. **Crew cab:** 90 amp alternator.
- 24 Volt, 4.5 kW starter motor.
- 2 x 115E41L (651 CCA) batteries connected in series.

Cabin Specifications and Appointments

CAB EXTERIOR

- All steel construction. High tensile steel used for cab underframe.
 - Single cab:** Manual cab tilt to 45° with torsion bar assistance.
 - Crew cab:** Electro-hydraulic cab tilt.
- **Single cab:** Liquid filled front and rear cab mounts. **Crew cab:** Rubber cab mounts.
- Heavy duty non slip entry steps.
- 90° opening internally reinforced front doors.
- Water spray suppression guards and front mudflaps.
- Laminated windscreen with shade band.
- Two speed windscreen wipers, with intermittent wipe mode.
- Halogen multi-reflector headlamps incorporating turn signals. Additional door mounted side indicator lamps.
- Combination brake, turn, reverse and marker lamps, registration plate illumination lamps. Extended wiring harness. Reverse alarm.
- Roof-mounted clearance lamps.
- Heated and powered exterior main mirrors with flat glass and additional powered convex "spot" mirrors.
- Body coloured grille.
- Body coloured steel bumper with front foglamps. Air dam type (except FRR 500 PTO). Standard type (FRR 500 PTO).

CAB INTERIOR

- Isri 6860 air suspension driver's seat with pneumatic lumbar support, height, rake and automatic weight adjustment.
- Front passenger adjustable bucket seat and front centre seat with folding seat back.
- **Crew cab:** Rear bench seat with 4 seat capacity.
- 3-point lap sash seatbelts in all outboard seating positions. Driver seatbelt with pretensioner integrated with driver seat. Centre seat lap belts.
- Driver airbag.
- **AMT Pack:** Driver's footrest.
- Door and roof pillar entry assist grips. **Crew cab:** Full width rear grab rail with ashtray.
- Full interior trim, padded roof lining and vinyl floor covering. Driver and passenger windscreen header storage shelf.
- Tilt/Telescopic adjustable steering column, soft feel urethane steering wheel.
- Electric windows.
- Central locking with remote keyless entry and immobiliser.
- Twin cup holders. 24V cigarette lighter. Dashboard hook.
- Front door mounted storage pockets and driver's side ashtray.
- Centre console box with storage tray. Fold down storage tray behind centre seat backrest.

- Front passenger glovebox.
- Fully integrated air conditioning and heater/demister with 4-speed fan and outlets for windscreen, side windows, face and floor.
- Fluorescent type interior lamp with On/Door/Off switch.
- 2 DIN, two speaker radio/CD multimedia unit with 4.8" LCD touch screen and Bluetooth. Provision for SD card, USB and 3.5 mm plug inputs.
- DIN sized compartment for storage or for CB radio installation.

DRIVER CONTROLS

- Key-operated engine start/stop and steering lock. Engine idle speed control.
- HSA slow/fast engagement control and on/off switch.
- ASR on/off (except crew).
- DPD regeneration.
- Hand held pendant for rear suspension raise and lower (FRD only).
- **AMT Pack:** AMT slow/fast gear engagement control, 1st gear start and normal/economy gear selection modes.
- **Left side combination stalk:** Windscreen wipers, washers and exhaust brake.
- **Right side combination stalk:** Turn signals, headlamps and cruise control.

INSTRUMENTATION

- Electronically driven speedometer and tachometer. Digital odometer with integrated dual tripmeter. Engine coolant temperature, fuel level and air pressure gauges.
- **Warning lamps:** Check engine, oil pressure, ABS, SRS airbag, alternator charge, service brakes, park brake, seatbelt unfastened, low air pressure, air suspension failure (FRD only), low fuel level, cab lock. **AMT Pack:** Check AMT.
- **Indicator lamps:** HSA, warm up system, high beam, ASR (except crew), DPD status, exhaust brake, turn signals, cruise control. **AMT Pack:** Econo-mode, 1st gear start.
- **AMT Pack:** Gear selection display.
- Multi-information display. Shows service interval, instantaneous and average fuel consumption, DPD bar chart, hourmeter, voltmeter, time/day/date and includes 40-120 km/h adjustable vehicle speed warning.

OPTIONS AND GENUINE ACCESSORIES

Include the following (extra cost, request a brochure and further details from your Isuzu dealer):

- Satellite navigation - integrates with multimedia unit and includes NAVTEQ mapping.
- Up to three audio/visual reversing cameras - integrates with multimedia unit.
- Airbag compatible bullbar.

Weights (kg)

Models	Ratings*		Loading Limit* (at ground)		Cab Chassis Mass#		
	GVM	GCM	Front	Rear	Front	Rear	Total
FRR 500 PTO	10,400	16,000	3,700	7,000	2,110	1,150	3,260
FRR 500 Medium	10,400	16,000	3,700	7,000	2,040	1,140	3,180
FRR 500 Medium AMT	10,400	16,000	3,700	7,000	2,055	1,145	3,200
FRR 500 Long	10,400	16,000	3,700	7,000	2,060	1,150	3,210
FRR 500 Long AMT	10,400	16,000	3,700	7,000	2,075	1,155	3,230
FRR 500 X-Long	10,400	16,000	3,700	7,000	2,110	1,175	3,285
FRD 500 X-Long	10,400	16,000	3,700	7,000	2,105	1,290	3,395
FRR 500 Crew	10,400	16,000	3,700	7,000	2,325	1,235	3,560
FRR 500 Crew AMT	10,400	16,000	3,700	7,000	2,340	1,240	3,580

* Vehicle ratings and front/rear weight limits are subject to government regulatory requirements and weight distribution analysis. Consult your Isuzu dealer to select the correct vehicle for your specific application.
Cab chassis only as supplied and including 10 litres of fuel.

Dimensions (mm)

Models	WB	OAL	FOH	ROH	EA	CE	RT	ORT	CH	FFA (unladen)	RFA (unladen)	RFH (unladen)	Turn Circle (m) KERB TO KERB
FRR 500 PTO	3,790	6,555	1,170	1,595	3,020	4,830	1,660	2,152	2,550	750	925	980	12.0
FRR 500 Medium	4,060	6,975	1,170	1,745	3,430	5,250	1,660	2,152	2,585	740	915	980	12.9
FRR 500 Long	4,660	7,875	1,170	2,045	4,030	6,150	1,660	2,152	2,585	740	915	985	14.8
FRR 500 X-Long	5,320	8,625	1,170	2,135	4,690	6,900	1,660	2,152	2,595	740	905	970	16.9
FRD 500 X-Long	5,320	8,625	1,170	2,135	4,690	6,900	1,660	2,152	2,595	740	775	775	16.9
FRR 500 Crew	5,160	8,605	1,170	2,275	3,450	5,848	1,660	2,152	2,595	730	905	985	16.4

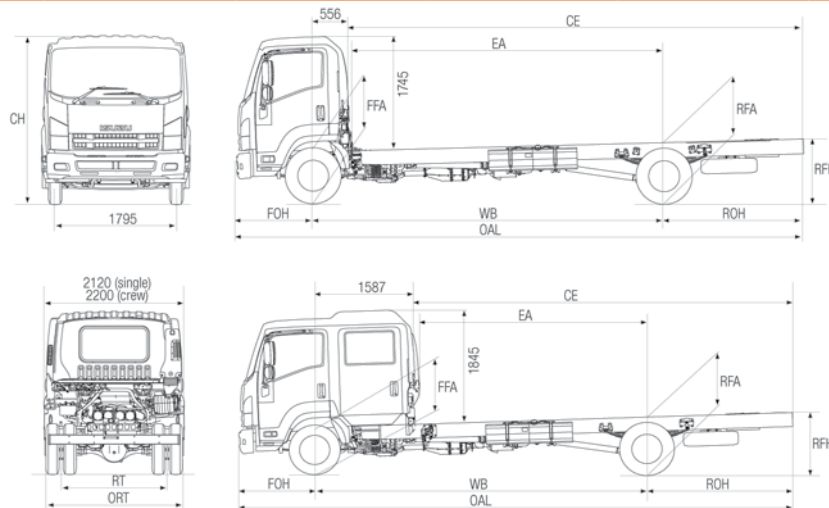

Performance (calculated - typical paved road)

		Geared Speed* (top gear at peak power engine RPM)	Low Speed Gradeability (lowest forward gear assuming no wheel slip)	Engine Speed (top gear at 100 km/h)
FRR / FRD 500	At 10,400 kg GVM	108 km/h @ 2,600 RPM	47%	2,415 RPM

*Maximum speed achievable depends on vehicle frontal area as well as other factors. Consult your Isuzu dealer for more detailed information.

Isuzu Warranties

STANDARD¹

New Vehicle	3 years 150,000 km 2,500 hrs
Cab Perforation Corrosion	3 years Unlimited km

EXTENDED²

4 years 250,000 km	5 years 300,000 km	6 years 350,000 km
----------------------	----------------------	----------------------

Order Codes

Model	Code	Model	Code
FRR 500 PTO	FH-FRRE-A03 (MU9)	FRR 500 X-Long	FH-FRRE-Y02 (MU9)
FRR 500 Medium	FH-FRRE-T02 (MU9)	FRD 500 X-Long	FH-FRDE-Y02 (MU9)
FRR 500 Medium AMT	FH-FRRE-G02 (MU9)	FRR 500 Crew	FH-FRRG-S02 (MU9)
FRR 500 Long	FH-FRRE-X02 (MU9)	FRR 500 Crew AMT	FH-FRRG-R02 (MU9)
FRR 500 Long AMT	FH-FRRE-Z02 (MU9)		

¹ Subject to the conditions outlined in the IAL New Vehicle Warranty, the Isuzu FRR and FRD models carry a standard factory warranty which covers the owner: (i) for the entire vehicle, for the first 36 months or 150,000 km or 2,500 hrs (whichever comes first), (ii) against cab perforation corrosion, for 36 months and unlimited kilometres. ² Extended Warranty as illustrated is available by purchase to cover the owner against the failure of original components, but may exclude some components and expendable items such as oil, filters, etc. Please consult with your Isuzu Dealer for full details obtained from a dedicated brochure available to customers.

ISUZU AUSTRALIA LIMITED ABN 97 006 962 572 ("IAL"). The information in this brochure was correct at time of printing, but all measurements, specifications and equipment are subject to change without notice. Some equipment may have been changed and/or is available at extra cost. IAL may make changes at any time without notice, in prices, colours, materials, equipment and models. IAL makes all reasonable attempts to ensure the availability of all vehicles and equipment. The information in this brochure is general in nature. Your Isuzu dealer can confirm all measurements, specifications and vehicle / equipment availability upon request.

November 2009. ARK0446